

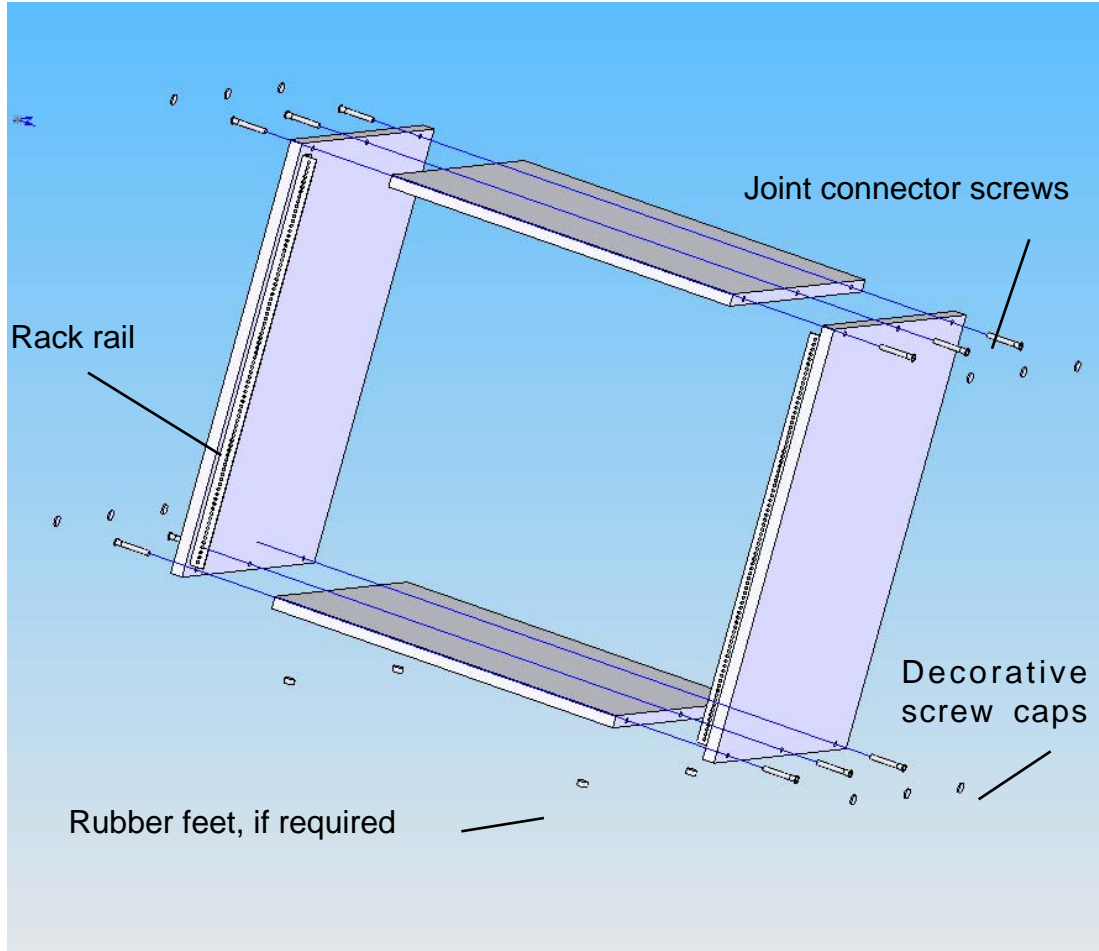

www.arnscott.com

RSE Series 19" Laminated Wood Rack Assembly Instructions

Install # I-RK-RSE
Revision # -0002-R.A



Assembly:

- 1.) Assemble rack as shown above however lie rack on its back.
- 2.) Partially tighten bolts first, then after all are installed do a final tighten.....do final cabinet alignment at this time.
- 3.) To make the screws install easier, apply a bit of liquid soap to the threads.
- 4.) Snap the plastic screw caps onto the screw heads.
- 5.) Attach rubber feet if required

Your AEG rack is now ready to stuff full of equipment. For full product specifications, please see www.arnscott.com

Parts List:

Qty:	Description:
2	Side Panels with rack rails
2	Top & bottom panels

Hardware Pack

12	Joint connector screws
12	Decorative screw caps
4	Rubber feet
1	Allen key for assembly

Note: RSE-416 requires only 8 joint connector screws and 8 decorative screw caps.

Note: Specifications are subject to change without notice.



A Division of Arnscott Electronics Inc.
211 Smith Street, Arthur, Ontario, Canada, N0G 1A0

Phone: (519) 848-1100
Fax: (519) 848-1101
www.arnscott.com
sales@arnscott.com