



HC Series

Horn Cage

Protective Covers to Protect Paging Horns

FEATURES

- Horn cage to fit AEG GPH / GAP Series of paging horns
- 1/4" (6mm) steel bar, bright zinc plated finish
- Base 17" (432mm) square, front 15" (381mm) square, depth 15" (381mm)
- Mounting provisions to accept 1/4" lag bolt or similar fastener
- Install paging horn to final position, then attach horn cage to structure.
- Weather-resistant

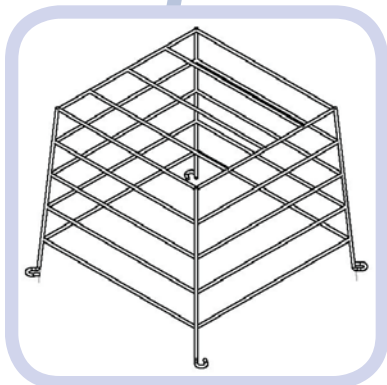

HC-1

HC Series

Cage to Protect AEG Paging Horns

HC Series

SPECIFICATIONS

Horns That fit:

GPH-415
 GPH-30
 GPH-60
 GAP-15T
 GAP-30T
 And any other Horn that is similar in size to our Paging Horns

Speakers That Fit:

This Cover will fit over almost any of AEG's 4 or 8" speakers, including Surface or Flush Mount.

Bells That Fit:

This cover will fit almost any motorized or electronic Bell.

Lighting that fits:

This cover will fit over a lot of lighting applications, however tests for shadows should be done to decide on acceptability.

Mounting Instructions:

Install and aim the Paging horn, then install the cage over top using 1/4" Lag type or similar Hardware.

HC-1

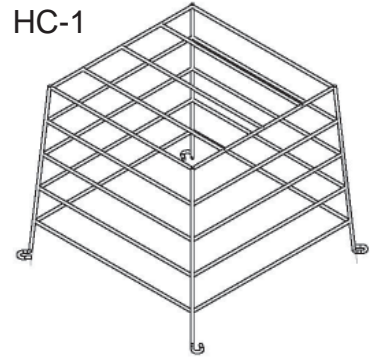

ARCHITECTS AND ENGINEERS SPECIFICATIONS

MODEL HC-1

The AEG Model HC-1 is a heavy duty cage designed to be installed over top of a paging horn, or other device that will physically fit, protecting it from objects like a basketball. The cage shall be fabricated from 1/4" (6 mm) steel bar stock, then plated with a bright zinc plating. The Cage shall measure 17" (432 mm) square at the base, 15" (381 mm) square at the front, and 15" (381 mm) deep. The HC-1 shall mount to the surface with 1/4" lag bolts or equivalent suitable hardware, which is not included. This cage is suitable for indoor or outdoor applications. The cage shall be used wherever a paging horn or other device requires protection, such as a school yard or gymnasium, a recreational center, a prison court yard or common area, any commercial application where the device requires protection. The model number shall be AEG HC-1.