



www.arnscott.com

www.arnscott.com

## Audio Attenuator Controls

"AT" Series



# AT Controls

## 70/25 Volt Controls

Professional commercial 70.7 and 25 volt audio line attenuator controls

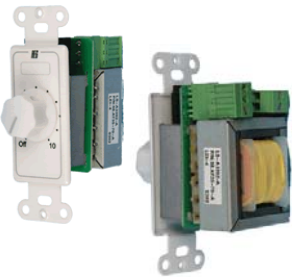

"DW" Series



"CM" Series



"DS" Series

### FEATURES

- For use in most commercial type installations where a 70 volt background music or paging system requires user access to the volume levels in their local zone.
- Stainless steel, "DW" & "DS" Series and Custom Mount (CM) options. The "DW" & "DS" Series allows multiple controls of various types to be installed into a "Control Panel" type installation.
- 3 dB per step attenuation with the exception of the last 2 steps, these are 6 dB per step to allow the control to attenuate even the most sensitive of loudspeakers.
- All AEG attenuators are equipped with a positive stop between off and full power to help protect the speaker from abuse.
- Need to 19" rack mount your controls? Take a look at our RM-52 panel. This 2 gang plate will hold up to 5 controls, CM or VC models for example!
- For Volume Controls that are either of the L-Pad or the wire wound type please see our separate technical note.

### SPECIFICATIONS - STAINLESS SERIES

AT Controls



AT10-70(-OR)  
AT35-70(-OR)



AT75-70(-OR)

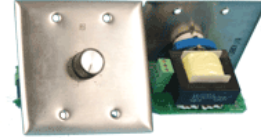

AT150-70(-OR)

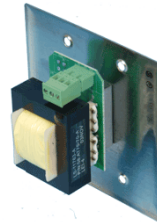

AT75-70

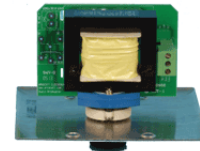

AT150-70



AT10-70-OR

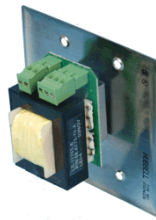

AT75-70-OR

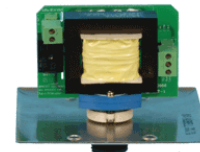

AT150-70-OR

Model	Power Rating Continuous Watts	Total Attenuation dB.	Insertion Loss dB.	Mounting Plate Size (# of gang)	Plate Type	Surface Mount Box Option	Depth
AT10-70(-OR)	10	33	0.5	1	Brushed Stainless	SM45	2"
AT35-70(-OR)	35	33	0.6	1	Brushed Stainless	SM45	2-1/4"
AT75-70(-OR)	75	33	0.6	2	Brushed Stainless	SM452	2-1/4"
AT150-70(-OR)	150	33	0.6	2	Brushed Stainless	SM452	2-1/4"

Note: designed for 70 Volt audio installations, attenuation curve is steeper for 25 volt installations.

There are 10 switch positions plus off.

Options: -70 = brushed stainless(SS) plate, black knob, -DSW = "D" style 1 gang, slide switch style, -DW = "D" style 1 gang plate, -OR = 24 vdc priority over-ride relay option

Attenuation of these models is: 7 stops x 3dB. & 2 stops x 6dB.

# AT Series

## Professional 70.7/25 volt audio line attenuation controls

### SPECIFICATIONS - DS & DW & CM SERIES

AT Controls



AT10-DSW(-OR)  
AT35-DSW(-OR)  
Shown with  
Optional DW-SS  
Trim Cover. Also  
available in Beige,  
Almond and Grey



AT10-DW(-OR)  
AT35-DW(-OR)  
Shown with  
Optional DW-WT  
Trim Cover

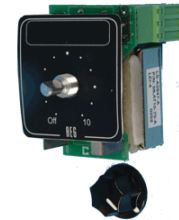

AT10-CM(-OR)  
AT35-CM(-OR)  
AT75-CM(-OR)  
AT150-CM(-OR)



AT35-DSW-OR  
(Also available  
in Beige,  
Almond and  
Grey)



AT35-DW-OR



AT10-CM  
AT35-CM



AT10-DSW-OR  
Back View

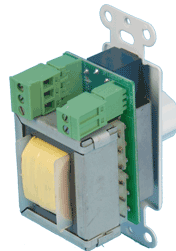

AT10-DW-OR



DSX Colours  
W - White  
A - Almond  
B - Beige

Model	Power Rating Continuous Watts	Total Attenuation dB.	Insertion Loss dB.	Mounting Plate Size (# of gang)	Plate Type	Surface Mount Box Option	Depth
AT10-DSW(-OR)	10	33	0.5	1 - Deep E/B	"D" Style Slide Switch	SM45	2"
AT10-DW(-OR)	10	33	0.5	1 w/trim plate	"D" Style	SM45	2"
AT10-CM(-OR)	10	33	0.5	Custom - (1)	Panel Mount-No Plate	-	2"
AT35-DSW(-OR)	35	33	0.5	1 - Deep E/B	"D" Style Slide Switch	SM45	2-1/4"
AT35-DW(-OR)	35	33	0.6	1 w/trim plate	"D" Style	SM45	2-1/4"
AT35-CM(-OR)	35	33	0.6	Custom - (1)	Panel Mount-No Plate	-	2-1/4"
AT75-CM(-OR)	75	33	0.6	Custom - (2)	Panel Mount-No Plate	-	2-1/4"
AT10-CM(-OR)	150	33	0.6	Custom - (2)	Panel Mount-No Plate	-	2-1/4"

Note: designed for 70 Volt audio installations, attenuation curve is steeper for 25 volt installations.

There are 10 switch positions plus off.

Options: -DSW = "D" style 1 gang, slide switch style, -DW = "D" style 1 gang plate, -OR = 24 vdc priority over-ride relay option  
Relays Draw 0.33W at 24vdc

DSW Series is available in White, Almond, Beige. DSW, DSA, DSB

Attenuation of these models is: 7 stops x 3dB. & 2 stops x 6dB.

# AT Series

## Professional 70.7/25 volt audio line attenuation controls

### SPECIFICATIONS - BLOCK SCHEMATIC

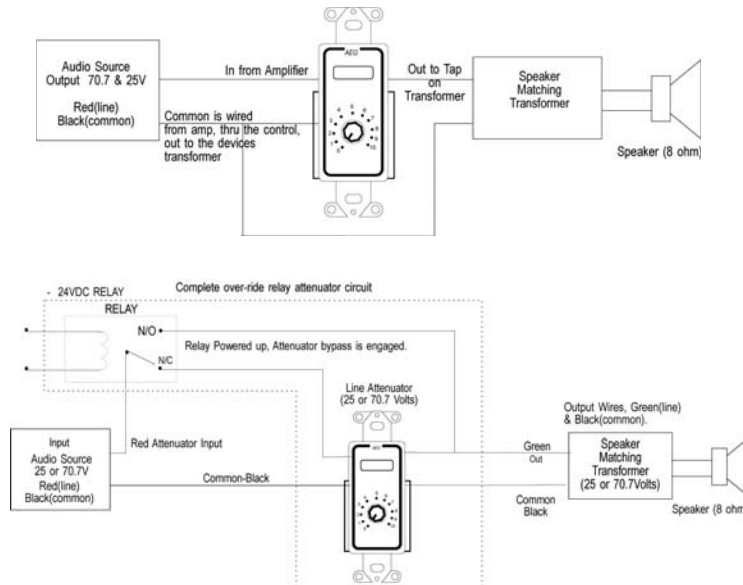

### ARCHITECTS AND ENGINEERS SPECIFICATIONS

#### MODEL AT10, AT35 & AT75

The attenuator shall be AEG Models as listed above. The unit shall have 10 steps of attenuation with a positive off. The stepped attenuation of these models shall be 7 stops of 3 dB. and 2 stops of 6 dB.. The maximum loudspeaker load on the attenuator shall be 10, 35, 75 or 150 Watt. The line voltage to be attenuated shall be 70.7v or 25v RMS (attenuation curve is steeper when used on a 25v system). Insertion loss is 0.5/0.6/0.6dB.. Frequency response for the 10 & 35 watt attenuators is 20-100 Hz +/- 2dB, 100-20,000 Hz, +/- 1dB. Frequency response for the 75 or 150 Watt attenuators is 20-100 Hz +/- 5dB, 100-20,000 Hz, +/- 2dB. The AT10 series shall have a maximum depth of 5.08cm (2"). The AT35, AT75 and AT150 Series shall have a maximum depth of 5.7cm (2-1/4"). For surface mounted applications these units shall mount to AEG Model SM45 or SM452(see chart above) wall box. For flat or recessed mounting, this unit shall mount to most deep single or 2-gang receptacle boxes as required that are equipped with 8.2cm (3-9/32") mounting centers. positive snap screw terminal connectors are standard on all models. Models AT150 require a deep Electrical box for installation. When panel mounting the AT150(-OR) "CM" models, use the RM42 Panel, not the RM52 panel which is used for all other "CM" models.

#### -OR Over-ride Models

The priority over-ride attenuators shall have the same specifications as the AT Series attenuators with the following additions: 24vdc relay that is factory installed. When separate 24vdc power is supplied to the relay, the attenuator position is over-ridden to produce a full on condition. The relay power consumption shall be 0.33 watts

#### -70 Models

The -70 model attenuators shall be mounted onto a 1 gang brushed stainless steel(SS) wall plate with 8.2cm (3-9/32") mounting centers. The 75 watt models are mounted onto a 2-gang plate.

#### -DS Models

The -DS Models attenuators are mounted onto 1 gang "D" style modular wall plates that mount to 8.2cm (3-9/32") mounting center electrical boxes. These unique controls are equipped with a slide type switch. Colours are Ultra White, Almond, Beige.

#### -DW Models

The -DW Models attenuators are mounted onto 1 gang "D" style modular wall plates that mount to 8.2cm (3-9/32") mounting center electrical boxes. Colour is Ultra White.

#### -CM Models

The -CM Models are supplied without a mounting plate, do come with a back printed permanent adhesive step indicator label and knob.